

EK 12 Narrow Aisle Forklift 48 V

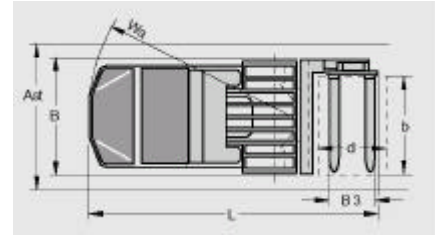
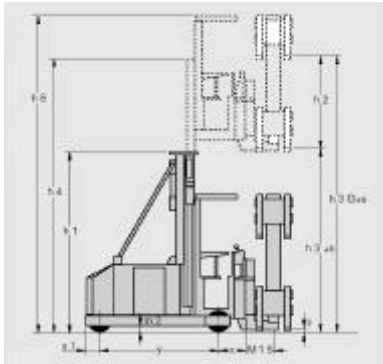

			EK 12
Built to suit Load & Application			
Load Capacity	Q	1200 kg	2645 lbs
Load Center	C	600 mm	24"
Controls	Electric	~AC	~ AC
Operator Position		stand / sit	stand / sit
Tires		polyurethane	polyurethane
Number of wheels (x=drive), load wheels		1x/2	1x/2
Drivers cabin entry height (lowered position)	h 8	400 mm	15.7"
Max. Fork elevation (h3 G + s)	h3 G + s	see specification tables	
Auxiliary lift (h2)	h 2	1700 mm	67"
Order Picking Height (h9)	h 9	h6 - 400 mm	h6 - 15.7"
Fork thickness / width (min. std)		40 / 120 mm	1.6 / 4.8"
Standard Fork lengths - increments of (10 mm) (0.4")		800 - 1300 mm	31.5 - 51.2"
External fork adjustment range (standard fork carriage 850 mm / 33.5")	B 3	505 - 795 mm	19.9 - 31.3"
Lowered height of forks (s)	s	80 mm	3.2"
Overall vehicle lengths (with standard 850 mm / 33.5" fork carriage)	L	3335 - 3425 - 3525 mm	131.3 - 134.8 - 138.8"
Overall vehicle lengths (with standard 580 mm / 22.8" fork carriage)	L	3200 - 3290 - 3390 mm	126.0 - 129.5 - 132.5"
Attachment arm length (to suit pallet width) standard dimensions	M 1 S	460 - 550 - 650 mm	18.1 - 21.7 - 25.6"
Overhang	X / X1	355 / 255 mm	13.8 / 10.0"
Overall chassis width (standard increments 50 mm / 2.0")	B	1200 - 1700 mm	47.2" - 67"
Collapsed height of lift mast	h 1	see specification tables	
Overall extended height of cabin	h 6	see specification tables	
Overall extended height of lift mast	h 4	see specification tables	
Turning radius	Wa	2140 mm	82.9"
Aisle width	Ast	1400 - 2000 mm	47.2 - 78.7"
Travel speed loaded / unloaded		10.0 / 10.0 km/h	6.2 / 6.2 mph
Lift speed loaded / unloaded		0.31 / 0.38 m/s	96 / 102 fpm
Lowering speed loaded / unloaded (adjustable)		0.40 / 0.40 m/s	79 / 79 fpm
Side shift speed loaded / unloaded (adjustable)		0.20 / 0.20 m/s	40 / 40 fpm
Vehicle weight including battery		4900 - 6300 kg	10,800 - 13,900 lbs
Axle load with rated load capacity drive / load		1600 / 4500; 2000 / 5500 kg	3,527 / 9,920; 4,409 / 12,125 lbs
Axle load without rated load capacity drive / load		2100 / 2800; 2500 / 3800 kg	4,630 / 6,173; 5,511 / 8,377 lbs
Tire dimension drive		343 / 140 mm	13.5 x 5.5"
Tire dimension load side		343 / 140 mm	13.5 x 5.5"
Wheel base	y	1840 mm	72.4"
Ground clearance center of wheel base	m 2	40 mm	1.6"
Operational brake		electro-magnetic	
Parking brake		deadman	
Battery Voltage / Capacity	V/Ah	48 V / 900 Ah	48 V / 900 Ah
Minimum Battery weight		1372 kg	3025 lbs
Drive Motor (KB 60 min)		5.0 kW	5.0 kW
Lift Motor		12.5 kW	12.5 kW
Motor controls		~ AC stepless technology	
Specifications subject to changes without prior notification			

Duplex Mast dimensions with turret attachment

										EK 12 - 48v	
Total Lift Height h3 G + s		Lift Height (main) h3 + s		Collapsed height h1		Mast extended h4		Auxiliary mast lift h2		Extended cab h6	
mm	in.	mm	in.	mm	in.	mm	in.	mm	in.	mm	in.
4200	165.4	2500	98.4	2495	98.2	3705	145.9	1700	67	4820	189.8
4700	185.0	3000	118.1	2745	108.1	4205	165.6	1700	67	5320	209.4
5200	204.7	3500	137.8	2995	117.9	4705	185.2	1700	67	5820	229.1
5700	224.4	4000	157.5	3245	127.8	5205	204.9	1700	67	6320	248.8
6200	244.1	4500	177.2	3495	137.6	5705	224.6	1700	67	6820	268.5
6700	263.8	5000	196.9	3745	147.4	6205	244.3	1700	67	7320	288.2
7200	283.5	5500	216.5	3995	157.3	6705	264.0	1700	67	7820	307.9
7700	303.1	6000	236.2	4245	167.1	7205	283.7	1700	67	8320	327.6
8200	322.8	6500	255.9	4495	177.0	7705	303.3	1700	67	8820	347.2
8700	342.5	7000	275.6	4745	186.8	8205	323.0	1700	67	9320	366.9
9200	362.2	7500	295.3	4995	196.7	8705	342.7	1700	67	9820	386.6
9700	381.9	8000	315.0	5245	206.5	9205	362.4	1700	67	10320	406.3

Additional heights available upon request

Triplex Mast dimensions with turret attachment

Total Lift Height h3 G + s		Lift Height (main) h3 + s		Collapsed height h1		Mast extended h4		Auxiliary mast lift h2		Extended cab h6	
mm	in.	mm	in.	mm	in.	mm	in.	mm	in.	mm	in.
6950	273.6	5250	206.7	2995	117.9	6440	253.5	1700	66.9	7570	298.0
7700	303.1	6000	236.2	3245	127.8	7190	283.1	1700	66.9	8320	327.6
8450	332.7	6750	265.7	3495	137.6	7940	312.6	1700	66.9	9070	357.1
9200	362.2	7500	295.3	3745	147.4	8690	342.1	1700	66.9	9820	386.6
9950	391.7	8250	324.8	3995	157.3	9440	371.7	1700	66.9	10570	416.1

Additional heights available upon request

Note: Overall vehicle length will increase by (35 mm) 1.4" with a 3 - stage mast

Aisle width relationship to Load dimension

Load dimensions		Clear Aisle Dimension	Attachment Arm Length	Vehicle Length 33.5" fork carriage	Intersecting Aisle w. 8" Safety Margin
Insertion	Width				
b	d	Ast	M 1 S	L	
in.	in.	in.	in.	in.	in.
48	32	66	18.1	131.3	151
48	40	66	21.7	134.8	155
48	48	66	25.6	138.8	162
40	48	58	25.6	138.8	158
32	48	56	25.6	138.8	158

Reduced vehicle length and aisle widths upon request

Aisle widths based on rail guided vehicles with 2-stage mast

EK 12 Narrow Aisle Forklift 80 V

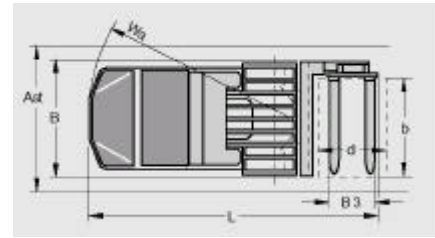
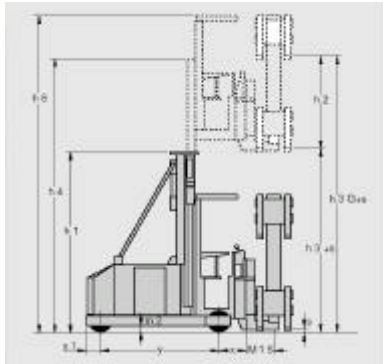

			EK 12
Built to suit Load & Application			
Load Capacity	Q	1200 kg	2645 lbs
Load Center	C	600 mm	24"
Controls	Electric	~AC	~ AC
Operator Position		stand / sit	stand / sit
Tires		polyurethane	polyurethane
Number of wheels (x=drive), load wheels		1x/2	1x/2
Drivers cabin entry height (lowered position)	h 8	400 mm	15.7"
Max. Fork elevation (h3 G + s)	h3 G + s	see specification tables	
Auxiliary lift (h2)	h 2	1700 mm	67"
Order Picking Height (h9)	h 9	h6 - 400 mm	h6 - 15.7"
Fork thickness / width (min. std)		40 / 120 mm	1.6 / 4.8"
Standard Fork lengths - increments of (10 mm) (0.4")		800 - 1300 mm	31.5 - 51.2"
External fork adjustment range (standard fork carriage 850 mm / 33.5")	B 3	505 - 795 mm	19.9 - 31.3"
Lowered height of forks (s)	s	80 mm	3.2"
Overall vehicle lengths (with standard 850 mm / 33.5" fork carriage)	L	3310 - 3400 - 3500 mm	130.3 - 133.8 - 137.8"
Overall vehicle lengths (with standard 580 mm / 22.8" fork carriage)	L	3175 - 3265 - 3365 mm	125.0 - 128.5 - 132.5"
Attachment arm length (to suit pallet width) standard dimensions	M 1 S	460 - 550 - 650 mm	18.1 - 21.7 - 25.6"
Overhang	X / X1	355 / 255 mm	13.8 / 10.0"
Overall chassis width (standard increments 50 mm / 2.0")	B	1200 - 1700 mm	47.2" - 67"
Collapsed height of lift mast	h 1	see specification tables	
Overall extended height of cabin	h 6	see specification tables	
Overall extended height of lift mast	h 4	see specification tables	
Turning radius	Wa	2140 mm	82.9"
Aisle width	Ast	1400 - 2000 mm	47.2 - 78.7"
Travel speed loaded / unloaded		10.0 / 10.0 km/h	6.2 / 6.2 mph
Lift speed loaded / unloaded		0.49 / 0.52 m/s	96 / 102 fpm
Lowering speed loaded / unloaded (adjustable)		0.40 / 0.40 m/s	79 / 79 fpm
Side shift speed loaded / unloaded (adjustable)		0.20 / 0.20 m/s	40 / 40 fpm
Vehicle weight including battery		4900 - 6300 kg	10,800 - 13,900 lbs
Axle load with rated load capacity drive / load		1600 / 4500; 2000 / 5500 kg	3,527 / 9,920; 4,409 / 12,125 lbs
Axle load without rated load capacity drive / load		2100 / 2800; 2500 / 3800 kg	4,630 / 6,173; 5,511 / 8,377 lbs
Tire dimension drive		343 / 140 mm	13.5 x 5.5"
Tire dimension load side		343 / 140 mm	13.5 x 5.5"
Wheel base	y	1840 mm	72.4"
Ground clearance center of wheel base	m2	40 mm	1.6"
Operational brake		electro-magnetic	
Parking brake		deadman	
Battery Voltage / Capacity	V/Ah	80 V / 450 Ah	80 V / 450 Ah
Minimum Battery weight		1238 kg	2730 lbs
Drive Motor (KB 60 min)		7.0 kW	7.0 kW
Lift Motor		21 kW	21 kW
Motor controls		~ AC stepless technology	
Specifications subject to changes without prior notification			

Duplex Mast dimensions with turret attachment

										EK 12 - 80v	
Total Lift Height h3 G + s		Lift Height (main) h3 + s		Collapsed height h1		Mast extended h4		Auxiliary mast lift h2		Extended cab h6	
mm	in.	mm	in.	mm	in.	mm	in.	mm	in.	mm	in.
4200	165.4	2500	98.4	2495	98.2	3705	145.9	1700	67	4820	189.8
4700	185.0	3000	118.1	2745	108.1	4205	165.6	1700	67	5320	209.4
5200	204.7	3500	137.8	2995	117.9	4705	185.2	1700	67	5820	229.1
5700	224.4	4000	157.5	3245	127.8	5205	204.9	1700	67	6320	248.8
6200	244.1	4500	177.2	3495	137.6	5705	224.6	1700	67	6820	268.5
6700	263.8	5000	196.9	3745	147.4	6205	244.3	1700	67	7320	288.2
7200	283.5	5500	216.5	3995	157.3	6705	264.0	1700	67	7820	307.9
7700	303.1	6000	236.2	4245	167.1	7205	283.7	1700	67	8320	327.6
8200	322.8	6500	255.9	4495	177.0	7705	303.3	1700	67	8820	347.2
8700	342.5	7000	275.6	4745	186.8	8205	323.0	1700	67	9320	366.9
9200	362.2	7500	295.3	4995	196.7	8705	342.7	1700	67	9820	386.6
9700	381.9	8000	315.0	5245	206.5	9205	362.4	1700	67	10320	406.3

Additional heights available upon request

Triplex Mast dimensions with turret attachment

Total Lift Height h3 G + s		Lift Height (main) h3 + s		Collapsed height h1		Mast extended h4		Auxiliary mast lift h2		Extended cab h6	
mm	in.	mm	in.	mm	in.	mm	in.	mm	in.	mm	in.
6950	273.6	5250	206.7	2995	117.9	6440	253.5	1700	66.9	7570	298.0
7700	303.1	6000	236.2	3245	127.8	7190	283.1	1700	66.9	8320	327.6
8450	332.7	6750	265.7	3495	137.6	7940	312.6	1700	66.9	9070	357.1
9200	362.2	7500	295.3	3745	147.4	8690	342.1	1700	66.9	9820	386.6
9950	391.7	8250	324.8	3995	157.3	9440	371.7	1700	66.9	10570	416.1

Additional heights available upon request

Note: Overall vehicle length will increase by (35 mm) 1.4" with a 3 - stage mast

Aisle width relationship to Load dimension

Load dimensions		Clear Aisle Dimension	Attachment Arm Length	Vehicle Length 33.5" fork carriage	Intersecting Aisle w. 8" Safety Margin
Insertion	Width				
b	d	Ast	M 1 S	L	
in.	in.	in.	in.	in.	in.
48	32	66	18.1	131.3	151
48	40	66	21.7	134.8	155
48	48	66	25.6	138.8	162
40	48	58	25.6	138.8	158
32	48	56	25.6	138.8	158

Reduced vehicle length and aisle widths upon request

Aisle widths based on rail guided vehicles with 2-stage mast