

**EK 13 Narrow Aisle Forklift 80 V**

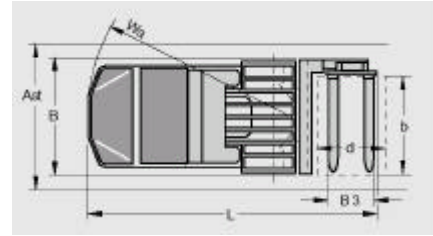
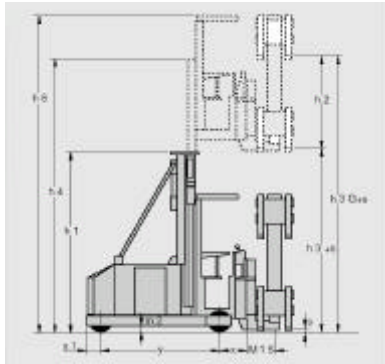

			EK 13
Built to suit Load & Application			
Load Capacity	Q	1300 kg	2865 lbs
Load Center	C	600 mm	24"
Controls	Electric	~AC	~ AC
Operator Position		stand / sit	stand / sit
Tires		polyurethane	polyurethane
Number of wheels (x=drive), load wheels		1x/2	1x/2
Drivers cabin entry height (lowered position)	h 8	400 mm	15.7"
Max. Fork elevation (h3 G + s)	h3 G + s	see specification tables	
Auxiliary lift (h2)	h 2	1700 mm	67"
Order Picking Height (h9)	h 9	h6 - 400 mm	h6 - 15.7"
Fork thickness / width (min. std)		40 / 120 mm	1.6 / 4.8"
Standard Fork lengths - increments of (10 mm) (0.4")		800 - 1300 mm	31.5 - 51.2"
External fork adjustment range (standard fork carriage 850 mm / 33.5")	B 3	505 - 795 mm	19.9 - 31.3"
Lowered height of forks (s)	s	80 mm	3.2"
Overall vehicle lengths (with standard 850 mm / 33.5" fork carriage)	L	3375 - 3465 - 3565 mm	132.8 - 136.4 - 140.4"
Overall vehicle lengths (with standard 580 mm / 22.8" fork carriage)	L	3240 - 3330 - 3430 mm	127.6 - 131.1 - 135.0"
Attachment arm length (to suit pallet width) standard dimensions	M 1 S	460 - 550 - 650 mm	18.1 - 21.7 - 25.6"
Overhang	X / X1	365 / 255 mm	14.4 / 10.0"
Overall chassis width (standard increments 50 mm / 2.0")	B	1200 - 1700 mm	47.2" - 67"
Collapsed height of lift mast	h 1	see specification tables	
Overall extended height of cabin	h 6	see specification tables	
Overall extended height of lift mast	h 4	see specification tables	
Turning radius	Wa	2170 mm	85.4"
Aisle width	Ast	1400 - 2000 mm	47.2 - 78.7"
Travel speed loaded / unloaded		10.0 / 10.0 km/h	6.2 / 6.2 mph
Lift speed loaded / unloaded		0.42 / 0.49 m/s	83 / 96 fpm
Lowering speed loaded / unloaded (adjustable)		0.40 / 0.40 m/s	79 / 79 fpm
Side shift speed loaded / unloaded (adjustable)		0.20 / 0.20 m/s	40 / 40 fpm
Vehicle weight including battery		5800 - 6900 kg	12,786 - 15,212 lbs
Axle load with rated load capacity drive / load		1800 / 5300; 2050 / 6150 kg	3,968 / 11,684; 4,519 / 13,558 lbs
Axle load without rated load capacity drive / load		2400 / 3400; 2700 / 4200 kg	5,291 / 7,496; 5,952 / 9,259 lbs
Tire dimension drive		343 / 140 mm	13.5 x 5.5"
Tire dimension load side		377 / 178 mm	14.8 x 7.0"
Wheel base	y	1880 mm	74.0"
Ground clearance center of wheel base	m 2	40 mm	1.6"
Operational brake		electro-magnetic	
Parking brake		deadman	
Battery Voltage / Capacity	V/Ah	80 V / 450 Ah **	80 V / 450 Ah **
Minimum Battery weight		1238 kg	2730 lbs
Drive Motor (KB 60 min)		7.0 kW	7.0 kW
Lift Motor		21 kW *	21 kW *
Motor controls		~ AC stepless technology	
Specifications subject to changes without prior notification			

\* Optional 26 kW Hydraulic Motor - lift speeds available upon request

\*\* Chassis can be extended to accept a 900 Ah battery

Duplex Mast dimensions with turret attachment

										EK 13 - 80v	
Total Lift Height h3 G + s		Lift Height (main) h3 + s		Collapsed height h1		Mast extended h4		Auxiliary mast lift h2		Extended cab h6	
mm	in.	mm	in.	mm	in.	mm	in.	mm	in.	mm	in.
5200	204.7	3500	137.8	2920	115.0	4630	182.3	1700	67	5820	229.1
5700	224.4	4000	157.5	3170	124.8	5130	202.0	1700	67	6320	248.8
6200	244.1	4500	177.2	3420	134.6	5630	221.7	1700	67	6820	268.5
6700	263.8	5000	196.9	3670	144.5	6130	241.3	1700	67	7320	288.2
7200	283.5	5500	216.5	3920	154.3	6630	261.0	1700	67	7820	307.9
7700	303.1	6000	236.2	4170	164.2	7130	280.7	1700	67	8320	327.6
8200	322.8	6500	255.9	4420	174.0	7630	300.4	1700	67	8820	347.2
8700	342.5	7000	275.6	4670	183.9	8130	320.1	1700	67	9320	366.9
9200	362.2	7500	295.3	4920	193.7	8630	339.8	1700	67	9820	386.6
9700	381.9	8000	315.0	5170	203.5	9130	359.4	1700	67	10320	406.3
10200	401.6	8500	334.6	5420	213.4	9630	379.1	1700	67	10820	426.0
10700	421.3	9000	354.3	5670	223.2	10130	398.8	1700	67	11320	445.7
11200	440.9	9500	374.0	5920	233.1	10630	418.5	1700	67	11820	465.4
11700	460.6	10000	393.7	6170	242.9	11130	438.2	1700	67	12320	485.0

Additional heights available upon request

Triplex Mast dimensions with turret attachment

Total Lift Height h3 G + s		Lift Height (main) h3 + s		Collapsed height h1		Mast extended h4		Auxiliary mast lift h2		Extended cab h6	
mm	in.	mm	in.	mm	in.	mm	in.	mm	in.	mm	in.
6000	236.2	7700	303.1	3170	124.8	7120	280.3	1700	66.9	8320	327.6
6750	265.7	8450	332.7	3420	134.6	7870	309.8	1700	66.9	9070	357.1
7500	295.3	9200	362.2	3670	144.5	8620	339.4	1700	66.9	9820	386.6
8250	324.8	9950	391.7	3920	154.3	9370	368.9	1700	66.9	10570	416.1
9000	354.3	10700	421.3	4170	164.2	10120	398.4	1700	66.9	11320	445.7

Additional heights available upon request

Note: Overall vehicle length will increase by (125 mm) 4.9" with a 3 - stage mast

Aisle width relationship to Load dimension

Load dimensions		Clear Aisle Dimension	Attachment Arm Length	Vehicle Length 33.5" fork carriage	Intersecting Aisle w. 8" Safety Margin
Insertion	Width				
b	d	Ast	M 1 S	L	
in.	in.	in.	in.	in.	in.
48	32	66	18.1	133.4	153
48	40	66	21.7	137.0	157
48	48	66	25.6	140.9	166
40	48	58	25.6	140.9	162
32	48	56	25.6	140.9	162

Reduced vehicle length and aisle widths upon request

Aisle widths based on rail guided vehicles with 2-stage mast