

EK 15 Narrow Aisle Forklift 80 V

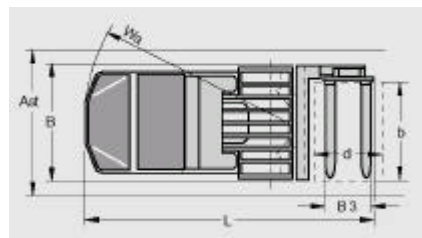
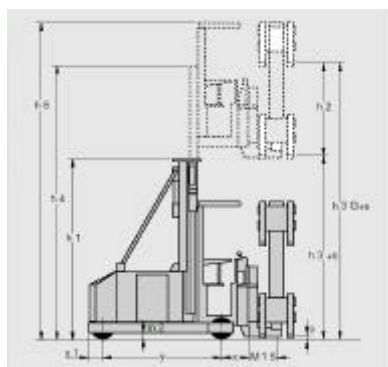

			EK 15
Built to suit Load & Application			
Load Capacity	Q	1500 kg	3300 lbs
Load Center	C	600 mm	24"
Controls	Electric	~AC	~ AC
Operator Position		stand / sit	stand / sit
Tires		polyurethane	polyurethane
Number of wheels (x=drive), load wheels		1x/2	1x/2
Drivers cabin entry height (lowered position)	h 8	400 mm	15.7"
Max. Fork elevation (h3 G + s)	h3 G + s	see specification tables	
Auxiliary lift (h2)	h 2	1700 mm	67"
Order Picking Height (h9)	h 9	h6 - 400 mm	h6 - 15.7"
Fork thickness / width (min. std)		40 / 120 mm	1.6 / 4.8"
Standard Fork lengths - increments of (10 mm) (0.4")		800 - 1300 mm	31.5 - 51.2"
External fork adjustment range (standard fork carriage 850 mm / 33.5")	B 3	505 - 795 mm	19.9 - 31.3"
Lowered height of forks (s)	s	80 mm	3.2"
Overall vehicle lengths (with standard 850 mm / 33.5" fork carriage)	L	3650 - 3740 - 3840 mm	143.7 - 147.2 - 151.2"
Overall vehicle lengths (with standard 580 mm / 22.8" fork carriage)	L	3515 - 3605 - 3705 mm	138.4 - 142.0 - 145.9"
Attachment arm length (to suit pallet width) standard dimensions	M 1 S	460 - 550 - 650 mm	18.1 - 21.7 - 25.6"
Overhang	X / X1	360 / 270 mm	14.2 / 10.6"
Overall chassis width (standard increments 50 mm / 2.0")	B	1200 - 1700 mm	47.2" - 67"
Collapsed height of lift mast	h 1	see specification tables	
Overall extended height of cabin	h 6	see specification tables	
Overall extended height of lift mast	h 4	see specification tables	
Turning radius	Wa	2445 mm	96.3"
Aisle width	Ast	1400 - 2000 mm	47.2 - 78.7"
Travel speed loaded / unloaded		10.0 / 10.0 km/h	6.2 / 6.2 mph
Lift speed loaded / unloaded		0.41 / 0.49 m/s	81 / 96 fpm
Lowering speed loaded / unloaded (adjustable)		0.40 / 0.40 m/s	79 / 79 fpm
Side shift speed loaded / unloaded (adjustable)		0.20 / 0.20 m/s	40 / 40 fpm
Vehicle weight including battery		7400 - 8300 kg	16,314 - 18,298 lbs
Axle load with rated load capacity drive / load		2490 / 6410; 2745 / 7055 kg	5,489 / 14,131; 6,052 / 15,553 lbs
Axle load without rated load capacity drive / load		2995 / 4405; 3360 / 4940 kg	6,602 / 9,711; 7,407 / 10,890 lbs
Tire dimension drive		381 / 152 mm	15.0 x 6.0"
Tire dimension load side		377 / 178 mm	14.8 x 7.0"
Wheel base	y	2140 mm	84.3"
Ground clearance center of wheel base	m 2	40 mm	1.6"
Operational brake		electro-magnetic	
Parking brake		deadman	
Battery Voltage / Capacity	V/Ah	80 V / 750 Ah **	80 V / 750 Ah **
Minimum Battery weight		1863 kg	4107 lbs
Drive Motor (KB 60 min)		7.0 kW	7.0 kW
Lift Motor		21 kW *	21 kW *
Motor controls		~ AC stepless technology	
Specifications subject to changes without prior notification			

* Optional 26 kW Hydraulic Motor - lift speeds available upon request

** Chassis can be extended to accept a 900 Ah battery

Duplex Mast dimensions with turret attachment

										EK 15 - 80v	
Total Lift Height h3 G + s		Lift Height (main) h3 + s		Collapsed height h1		Mast extended h4		Auxiliary mast lift h2		Extended cab h6	
mm	in.	mm	in.	mm	in.	mm	in	mm	in	mm	in
5200	204.7	3500	137.8	2920	115.0	4630	182.3	1700	67	5820	229.1
5700	224.4	4000	157.5	3170	124.8	5130	202.0	1700	67	6320	248.8
6200	244.1	4500	177.2	3420	134.6	5630	221.7	1700	67	6820	268.5
6700	263.8	5000	196.9	3670	144.5	6130	241.3	1700	67	7320	288.2
7200	283.5	5500	216.5	3920	154.3	6630	261.0	1700	67	7820	307.9
7700	303.1	6000	236.2	4170	164.2	7130	280.7	1700	67	8320	327.6
8200	322.8	6500	255.9	4420	174.0	7630	300.4	1700	67	8820	347.2
8700	342.5	7000	275.6	4670	183.9	8130	320.1	1700	67	9320	366.9
9200	362.2	7500	295.3	4920	193.7	8630	339.8	1700	67	9820	386.6
9700	381.9	8000	315.0	5170	203.5	9130	359.4	1700	67	10320	406.3
10200	401.6	8500	334.6	5420	213.4	9630	379.1	1700	67	10820	426.0
10700	421.3	9000	354.3	5670	223.2	10130	398.8	1700	67	11320	445.7
11200	440.9	9500	374.0	5920	233.1	10630	418.5	1700	67	11820	465.4
11700	460.6	10000	393.7	6170	242.9	11130	438.2	1700	67	12320	485.0
12200	480.3	10500	413.4	6420	252.8	11630	457.9	1700	67	12820	504.7
12700	500.0	11000	433.1	6670	262.6	12130	477.6	1700	67	13320	524.4
13200	519.7	11500	452.8	6920	272.4	12630	497.2	1700	67	13820	544.1
13700	539.4	12000	472.4	7170	282.3	13130	516.9	1700	67	14320	563.8

Additional heights available upon request

Triplex Mast dimensions with turret attachment

Total Lift Height h3 G + s		Lift Height (main) h3 + s		Collapsed height h1		Mast extended h4		Auxiliary mast lift h2		Extended cab h6	
mm	in.	mm	in.	mm	in.	mm	in.	mm	in.	mm	in.
6800	267.7	5100	200.8	3170	124.8	6520	256.7	1700	66.9	7420	292.1
7550	297.2	5850	230.3	3420	134.6	7270	286.2	1700	66.9	8170	321.7
8300	326.8	6600	259.8	3670	144.5	8020	315.7	1700	66.9	8920	351.2
9050	356.3	7350	289.4	3920	154.3	8770	345.3	1700	66.9	9670	380.7
9800	385.8	8100	318.9	4170	164.2	9520	374.8	1700	66.9	10420	410.2
10550	415.4	8850	348.4	4420	174.0	10270	404.3	1700	66.9	11170	439.8
11300	444.9	9600	378.0	4670	183.9	11020	433.9	1700	66.9	11920	469.3
12050	474.4	10350	407.5	4920	193.7	11770	463.4	1700	66.9	12670	498.8
12800	503.9	11100	437.0	5170	203.5	12520	492.9	1700	66.9	13420	528.3
13550	533.5	11850	466.5	5420	213.4	13270	522.4	1700	66.9	14170	557.9

Additional heights available upon request

Note: Overall vehicle length will increase by (115 mm) 4.5" with a 3 - stage mast

Aisle width relationship to Load dimension

Load dimensions		Clear Aisle	Attachment Arm	Vehicle Length	Intersecting Aisle
Insertion	Width	Dimension	Length	33.5" fork carriage	w. 8" Safety Margin
b	d	Ast	M 1 S	L	
in.	in.	in.	in.	in.	in.
48	32	68	21.7	147.2	170
48	40	68	21.7	147.2	170
48	48	68	25.6	151.2	177
40	48	60	25.6	151.2	174
32	48	56	25.6	151.2	174

Reduced vehicle length and aisle widths upon request

Aisle widths based on rail guided vehicles with 2-stage mast